

ROADSTAR 2000 LAYOUT - OPTION 4

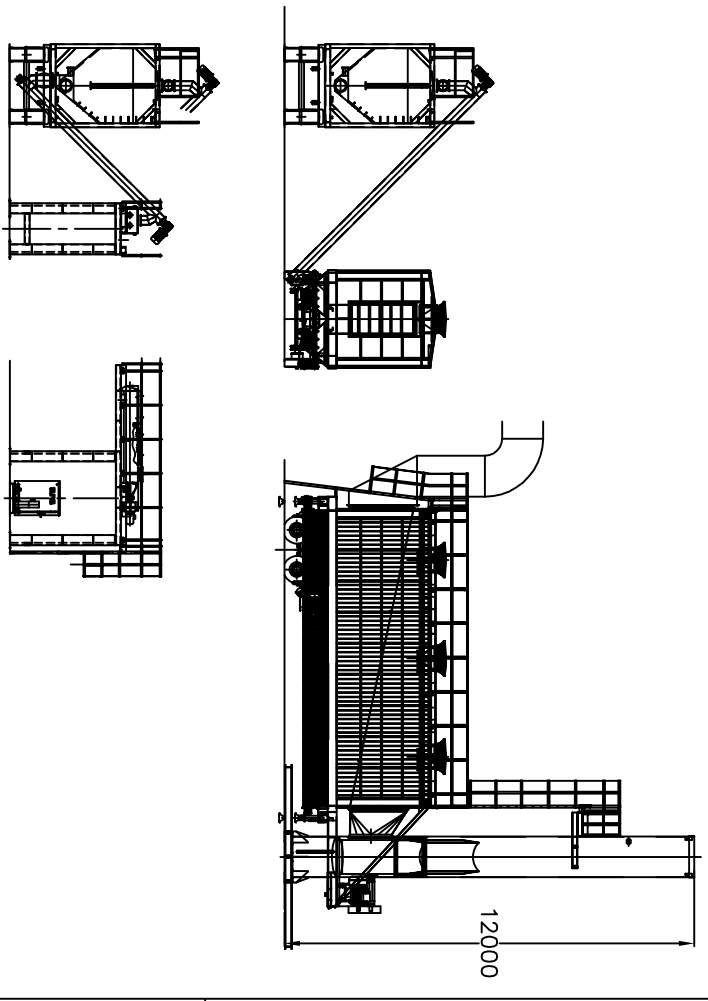
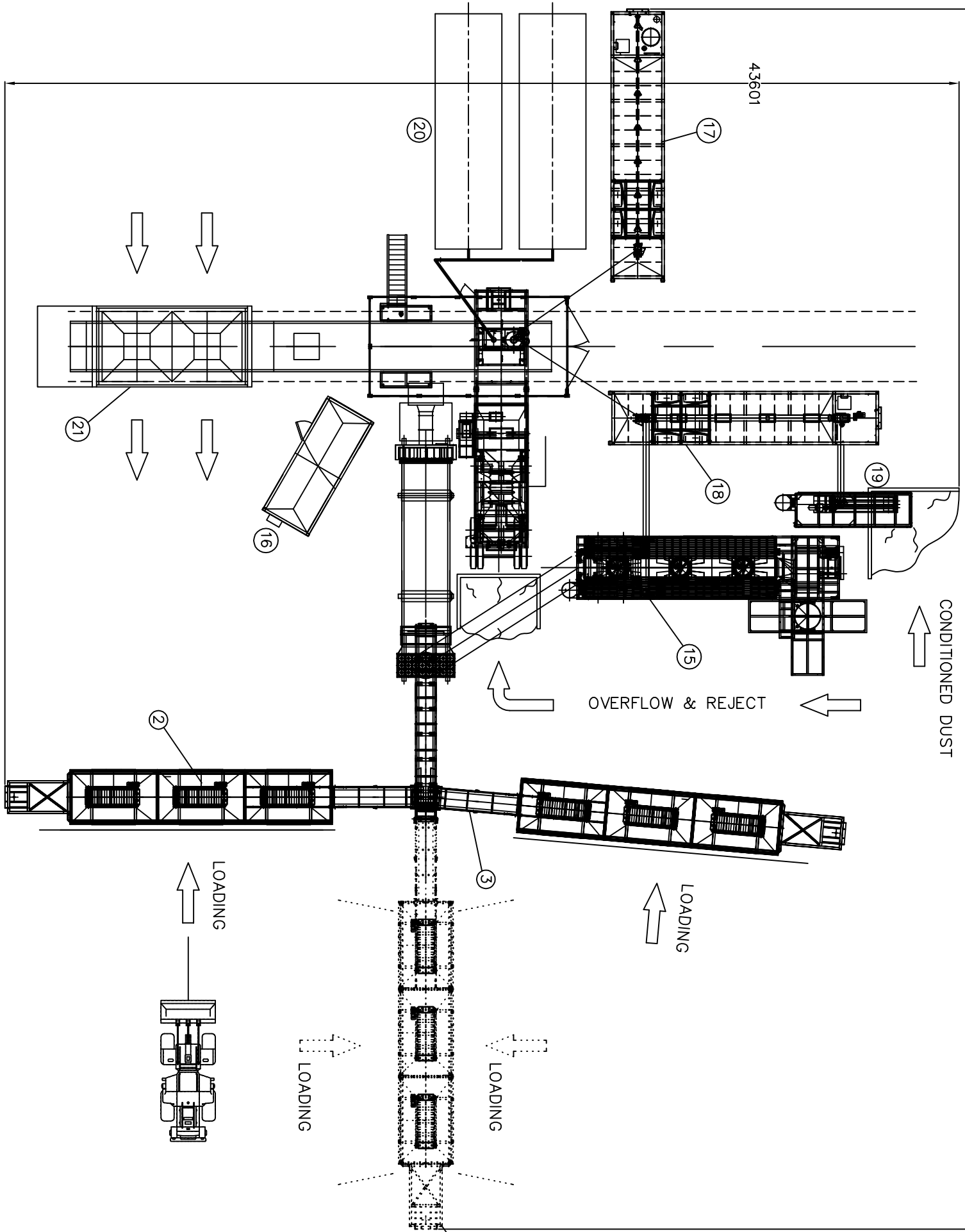
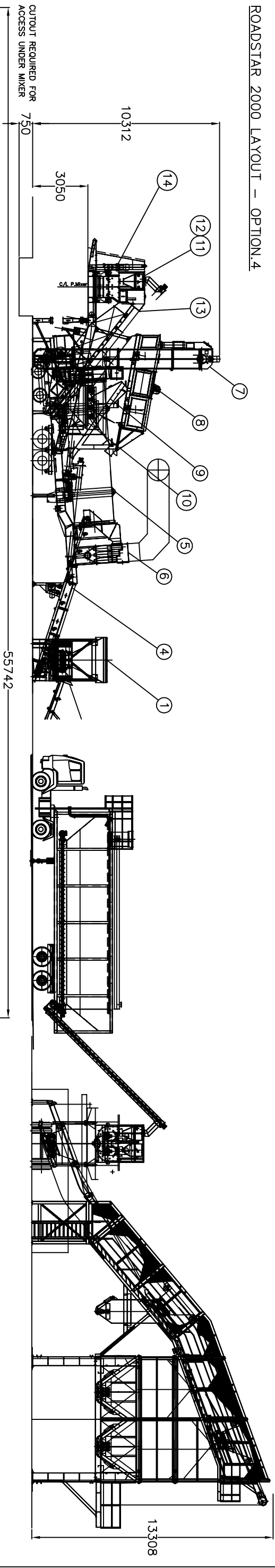

REF. DESCRIPTION

- 2 X 3-BIN 4M WIDE 7/10cUM FEED HOPPER
- 650MM WIDE X 1.8M CRS BELT FEEDER (4KW)
- 650MM WIDE S BEND COLLECTING CONVEYOR (7.5KW)
- 650MM WIDE DRYER FEED CONVEYOR
- 2.2 DIA X 8.0M ROTARY DRYER (4 X 15KW)
- PRIMARY DUST COLLECTION - MULTI CYCLONES
- 410MM WIDE BUCKET ELEVATOR (11KW)
- 1.8M WIDE X 5M 2 DECK SCREEN (11KW)
- 4 COMPARTMENT STORAGE HOPPER - 17.7TONNE CAPACITY
- AGGREGATE WEIGH HOPPER - 2250KG CAPACITY
- FILLER WEIGH HOPPER - 350KG CAPACITY
- BITUMEN WEIGH HOPPER - 300KG CAPACITY
- 1300MM WIDE BATCH ELEVATOR (7.5KW)
- 2000KG PADDLER MIXER (2 X 22KW)
- SECONDARY DUST FILTER - 72590 CUM/HR
- CONTROL CABIN - 5M X 2.4M
- 45cUM HORIZONTAL IMPORTED SILO (11KW)
- 45cUM HORIZONTAL RECLAIMED SILO (11KW)
- DUST CONDITIONER (11KW)
- 2 X 50,000 LITRES HORIZONTAL BITUMEN TANKS
- 2 X 50,000 LITRES HORIZONTAL STORAGE TANKS (SPUIT 50/70)

UNFINISHED DIMENSION OF
DIMENSION OF
UNITS IN MILLIMETRES UNLESS
OTHERWISE STATED

WELDING TERMS & SYMBOLS TO BS EN 22553:1995

ALL LIFTING BRACKET WELDS TO BE 100% NDT.

MINIMUM MATERIAL STANDARDS AS FOLLOWS -
STEEL - BS EN 10028-2
WELDS - BS EN 10025-2
BITUMEN TANKS - BS EN 10025-2

UNFINISHED DIMENSION OF	NOMINAL DIMENSION RANGE	UNITS IN MILLIMETRES UNLESS OTHERWISE STATED
10	10	mm
20	20	mm
30	30	mm
40	40	mm
50	50	mm
60	60	mm
70	70	mm
80	80	mm
90	90	mm
100	100	mm
150	150	mm
200	200	mm
250	250	mm
300	300	mm
350	350	mm
400	400	mm
450	450	mm
500	500	mm
550	550	mm
600	600	mm
650	650	mm
700	700	mm
750	750	mm
800	800	mm
850	850	mm
900	900	mm
950	950	mm
1000	1000	mm
1500	1500	mm
2000	2000	mm
2500	2500	mm
3000	3000	mm
3500	3500	mm
4000	4000	mm
4500	4500	mm
5000	5000	mm
5500	5500	mm
6000	6000	mm
6500	6500	mm
7000	7000	mm
7500	7500	mm
8000	8000	mm
8500	8500	mm
9000	9000	mm
9500	9500	mm
10000	10000	mm
15000	15000	mm
20000	20000	mm
25000	25000	mm
30000	30000	mm
35000	35000	mm
40000	40000	mm
45000	45000	mm
50000	50000	mm
55000	55000	mm
60000	60000	mm
65000	65000	mm
70000	70000	mm
75000	75000	mm
80000	80000	mm
85000	85000	mm
90000	90000	mm
95000	95000	mm
100000	100000	mm

ROADSTAR 2000
FOR LAGAN INTERNATIONAL

Phoenix Transworld Ltd

DRAWING NO. PP1066V3

DATE: 26/03/03
SCALE: 1:75